

A wireframe model of a car wheel, showing the intricate mesh structure of the rim and spokes. The wheel is rendered in a light blue color against a dark background.

TESTING REPORT

**Measurements of the polar moment of
inertia of automotive rims**

Warsaw, September 2023
Andrzej Dębowski, Ph.D.

INTRODUCTION



The tire wheel of a car is an assembly that is subjected to significant dynamic loads during driving and whose properties significantly affect the stability of movement, braking behavior of the vehicle, driving comfort, resistance to movement, transmission efficiency, etc. Therefore, the properties of wheels are studied primarily as a part of whole vehicle motion tests. In addition, bench tests of the wheels themselves are carried out to identify certain properties of the wheels - functional and strength characteristics. One of the basic parameters describing wheels determined on test stands is the polar moment of inertia. It varies depending on the mass and shape of the object under test, so it must be measured independently for both, the whole wheel and the wheel rim.



It is worth distinguishing between two concepts that often appear, i.e. polar moment of inertia and mass moment of inertia. Although similar, these are two different concepts related to the rotational motion of rigid bodies.



Mass moment of inertia

The mass moment of inertia is a measure of how difficult it is to change the motion of rotation of a rigid body around an axis. This means that the greater the mass moment of inertia of a given body about a particular axis of rotation is, the more difficult it is to change the angular velocity of that body around that axis. The moment of inertia depends on the distribution of the mass of the body with respect to the axis of rotation. For a body with a uniform distribution of mass around the axis of rotation, the moment of inertia can be calculated using appropriate formulas depending on the shape of the body and the axis of rotation.

Polar moment of inertia

The polar moment of inertia, also called the moment of inertia with respect to its polar axis, is a specific case of the moment of inertia. It applies only to rotational motion about an axis that is perpendicular to the plane of motion. In other words, the polar moment of inertia measures the difficulty of changing the rotational motion of a body around its polar axis. This is especially important when the body is moving like a rotor.

The determination of the polar moment of inertia can be carried out theoretically and with the help of appropriate test rigs. In the first case, it is possible to use CAD software, the mathematical method of disks and rings or the Steiner method, while in the second case it is possible to use a moving platform, energy balance or the vibration period method. Given the research capabilities at hand, the latter method - the vibration period - was used.

Mass moment of inertia is a more general concept and refers to the rotational motion of a body about any axis, while polar moment of inertia refers only to rotational motion about an axis perpendicular to the plane of motion



Research methodology



The oscillation period method is an indirect method used to determine the polar moment of inertia of an object, and in order to obtain the desired value, one must use the formula below and the corresponding test rig described next.

$$J = \frac{m \cdot g \cdot R \cdot r}{4 \cdot \pi^2 \cdot l} \cdot T$$

Where:

m - the mass of the wheel [kg];

g - acceleration of the earth [m/s^2];

R - distance of the lower cable attachment from the axis of rotation [m];

r - distance of the upper cable attachment from the axis of rotation [m];

l - cable length [m];

T - oscillation period [s].



The main part of the test stand (Figure 1) consists of an upper mounting plate, cables, a lower mounting plate and measuring apparatus (laser distance sensor, measuring card, stabilized laboratory power supply, laptop).

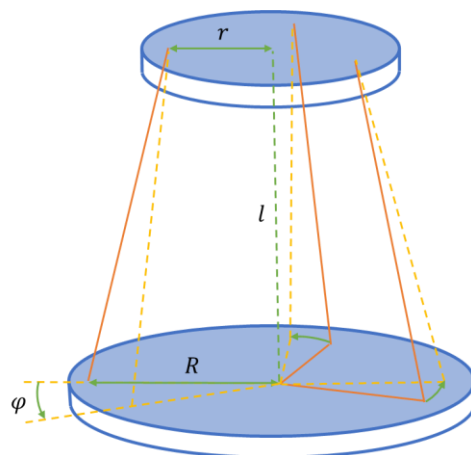

Figure 1: Schematic diagram of the test stand

To use the formula written earlier, it is necessary to determine the period of vibration. To do this, the object under test is placed on a plate or fixed under it, and by tilting the object together with the fixing plate by a small angle φ the system is made to vibrate. Then, using either a stopwatch or a laser transducer, the period of oscillation is measured. In this case, a laser distance transducer HG-C1400-P and NI USB DAQmx 6009 measurement card were used. In this way, the displacements of the marker, placed on the rim of the wheel, were recorded, obtaining time waveforms analogous to the following (Figure 2).

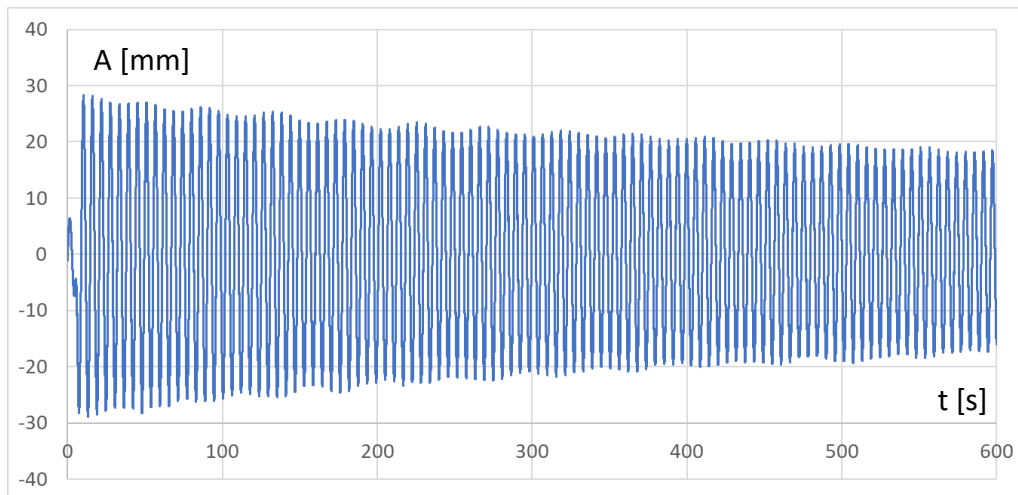

Figure 2: View of an example of the recorded vibration waveform of the system

The measurement was carried out for 600 s, which made it possible to record 80-160 periods of vibration, thus precisely determining the duration of a single period of vibration T (with an accuracy of 0.01 s). In order to increase the precision of the measurement, the distance between the mounting plates was measured each time using a rangefinder due to their different tensions resulting

from the different masses of the rims. In addition, due to the significant mass of the mounting plate, its polar moment of inertia was determined in two cases (suspended from three cables and from two cables with a rod), and its value was subtracted from the polar moment of inertia of the rim-disc system.

Depending on the plane of measurement, two- or three-line attachment was used, which does not change the idea of measurement and calculation.



In the further part, the local coordinate system shown in the figure below was used.

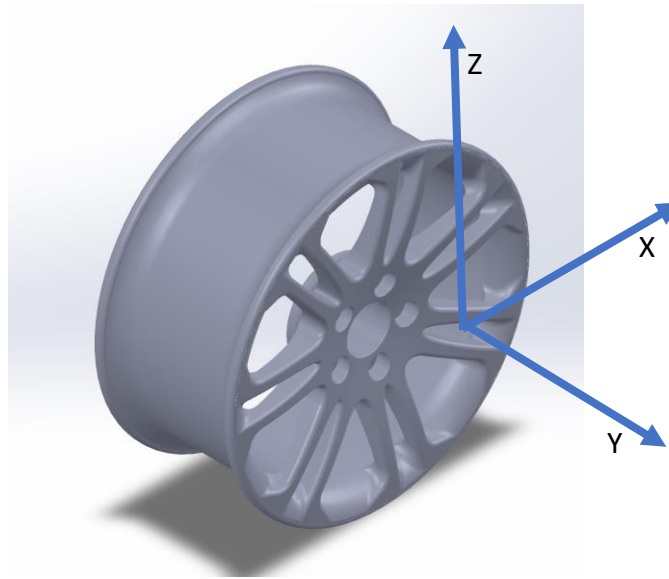

Figure 3: View of the wheel rim with the local coordinate system adopted

Table 1. List of apparatus used

Device name	Model	Measuring range
Distance transmitter	HG-C1400-P	$(200 \div 600 \pm 0,8)$ mm
Distance meter	Leica DISTO D3a	$(0,05 \div 100 \pm 0,001)$ m
Measuring card	NI USB DAQmx 6009	$(-5 \div 5 \pm 0,0006)$ V
Laboratory scales	RADWAG WLC 30/F1/R	$(0 \div 30000 \pm 0,5)$ g
Power supply	Korad KD3005D	$0 \div 30$ V, $0 \div 5$ A



Measurement results



Composite rim

Table 2. Summary of results for polar moment of inertia relative to the Y axis of the wheel rim

Testing object	Weight [kg]	R [m]	r [m]	l [m]	T [s]	J_Y [kg·m ²]
Fixing plate	5,2380	0,1343	0,1155	6,719	4,1462	0,052 ± 0,001
Composite rim	6,0605	0,1343	0,1155	6,720	5,8133	0,167 ± 0,001



Table 3. Summary of results for polar moment of inertia relative to the X and Z axes of the wheel rim

Testing object	Weight [kg]	R [m]	r [m]	l [m]	T [s]	J_X, J_Z [kg·m ²]
Fixing plate	5,8075	0,2	0,1	6,703	3,4953	0,053 ± 0,001
Composite rim	6,0605	0,2	0,1	6,706	4,1843	0,0101 ± 0,001



Alloy rim

Table 4. Summary of results for polar moment of inertia relative to the Y axis of the wheel rim

Testing object	Weight [kg]	R [m]	r [m]	l [m]	T [s]	J_Y [kg·m ²]
Fixing plate	5,2380	0,1343	0,1155	6,719	4,1462	0,052 ± 0,001
Aluminum rim	10,2040	0,1343	0,1155	6,723	6,0484	0,272 ± 0,001

Table 5. Summary of results for polar moment of inertia relative to the X and Z axes of the wheel rim

Testing object	Weight [kg]	R [m]	r [m]	l [m]	T [s]	J_x, J_z [kg·m ²]
Fixing plate	5,8075	0,2	0,1	6,703	3,4953	0,053 ± 0,001
Aluminum rim	10,2040	0,2	0,1	6,709	4,2190	0,161 ± 0,001



Steel rim

Table 6. Summary of results for polar moment of inertia relative to the Y axis of the wheel rim

Testing object	Weight [kg]	R [m]	r [m]	l [m]	T [s]	J_y [kg·m ²]
Fixing plate	5,2380	0,1343	0,1155	6,719	4,1462	0,052 ± 0,001
Steel rim	12,1060	0,1343	0,1155	6,725	6,5579	0,378 ± 0,001



Table 7. Summary of results for polar moment of inertia relative to the X and Z axes of the wheel rim

Testing object	Weight [kg]	R [m]	r [m]	l [m]	T [s]	J_x, J_z [kg·m ²]
Fixing plate	5,8075	0,2	0,1	6,703	3,4953	0,053 ± 0,001
Steel rim	12,1060	0,2	0,1	6,713	4,5119	0,222 ± 0,001

Table 8. Summary of results for polar moment of inertia with respect to the Y axis of the wheel rim

Testing object	Weight [kg]	R [m]	r [m]	l [m]	T [s]	J_Y [kg·m ²]
Fixing shield	5,2380			6,719	4,1462	0,052 ± 0,001
Composite rim	6,0605			6,720	5,8133	0,167 ± 0,001
Aluminum rim	10,2040	0,1343	0,1155	6,723	6,0484	0,272 ± 0,001
Steel rim	12,1060			6,725	6,5579	0,378 ± 0,001



Table 9. Summary of results for polar moment of inertia with respect to the X and Z axes of the wheel rim

Testing object	Weight [kg]	R [m]	r [m]	l [m]	T [s]	J_X, J_Z [kg·m ²]
Fixing shield	5,8075			6,703	3,4953	0,053 ± 0,001
Composite rim	6,0605			6,706	4,1843	0,101 ± 0,001
Aluminum rim	10,2040	0,2	0,1	6,709	4,2190	0,161 ± 0,001
Steel rim	12,1060			6,713	4,5119	0,222 ± 0,001

